

#9370 Adapter Plate Kit Instructions

Direct mounting of rocket-type fluid sensor to oil tank

Kit includes:

- (2) 8-32 x 1/2" Screws
- (1) Rocket Gasket
- (3) Plate Gaskets
- (1) Adapter Plate
- (2) 6-32 x 2" Screws and wing nuts

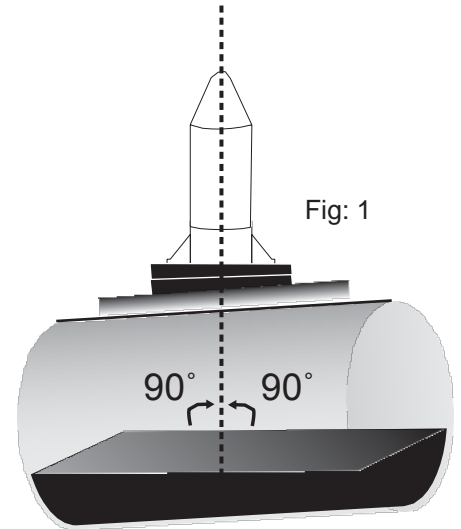
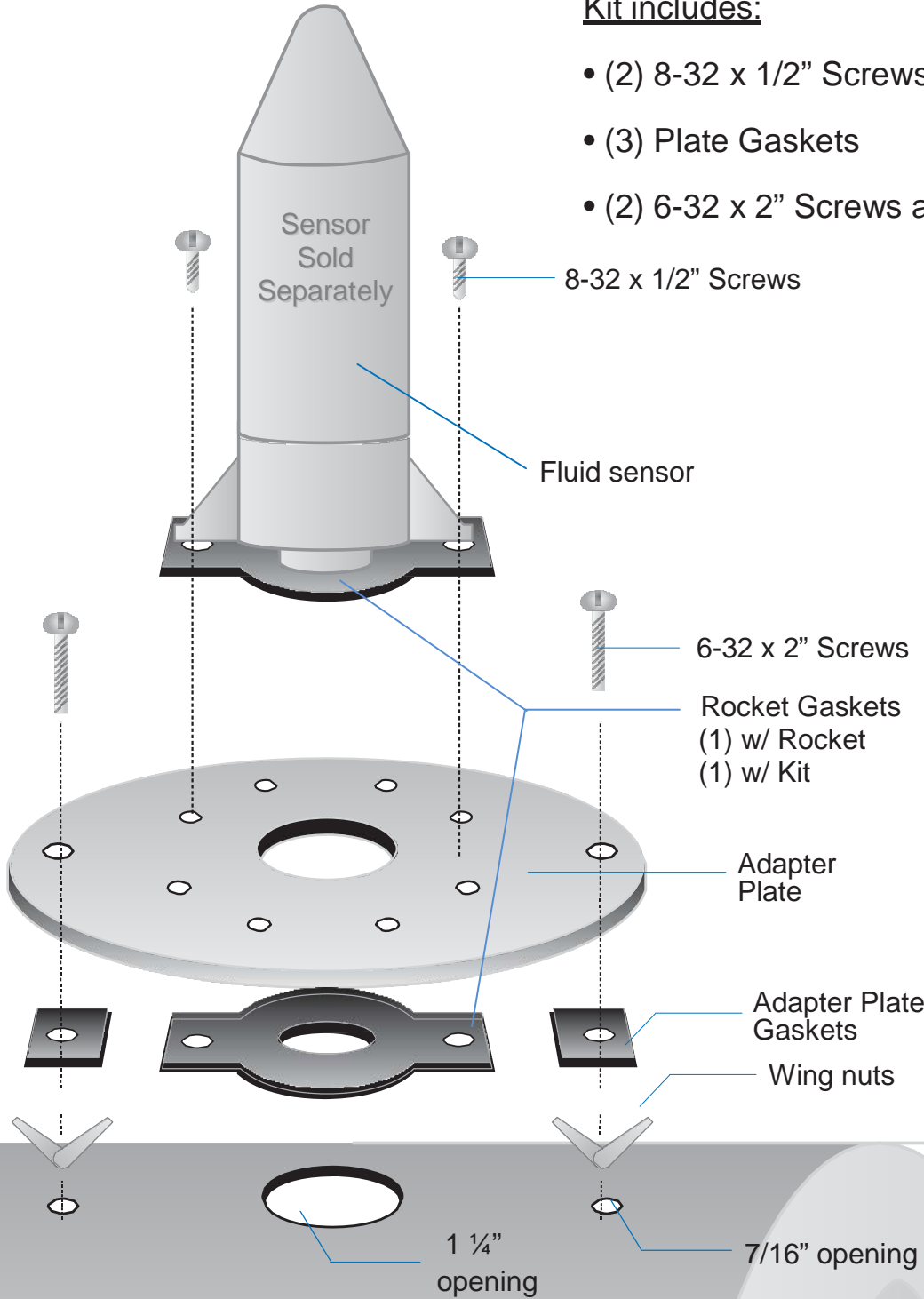

Fig: 1

- For best performance the "rocket" sensor should be mounted plumb (perpendicular to the surface of the liquid being mounted).
- Proper alignment can be achieved by selecting the best set of rocket mounting holes on the plate, and then tightening the rocket's screws to bring the alignment into plumb. See Fig: 1

Tools Needed:

- Phillips screwdriver
- 7/16" drill
- 1 1/4" drill